

A Dynamic Parameter Estimation Experiment That Is Remotely Accessible Via Internet

Richard J. Kozick Maurice F. Aburdene
Bucknell University

Abstract

A dynamic parameter estimation experiment for first-order systems is described. A novel feature of the experiment is its accessibility for remote execution via the Internet. The concept of a remotely shared laboratory has been proposed as a way to use readily available communication facilities to share expensive laboratory facilities among several universities. The dynamic parameter estimation experiment described here is a prototype of remotely shared laboratory exercises that are safe and inexpensive.

1 Introduction

The concept of a remotely shared laboratory has been proposed previously [1] as a way to use readily available communication facilities to share expensive laboratory facilities among several universities. The laboratory at Bucknell University contains digital signal processing units from dSPACE corporation and Sun workstations. Each dSPACE unit [2] consists of four A/D and D/A channels and a digital signal processor. In addition, each dSPACE unit is directly connected to the Internet, which facilitates the remote access to the experiments. The dSPACE units can be programmed through Matlab, Simulink, or C language.

The objective of the experiment is to estimate the parameters (gain and time constant) of a first-order RC circuit by applying Taylor series from calculus, least-squares analysis, and statistical analysis of experiments. A program can be downloaded to the dSPACE unit through the Internet that applies a step function input to the circuit and then acquires the resulting time response. The circuit parameters are then estimated from the measured data using a recursive time-domain approach similar to that described in [3]. The user can execute the estimation procedure through the Internet interface and study aspects of its operation, such as convergence and performance with real data. A related frequency-domain parameter estimation procedure is described in [4].

2 Laboratory Environment

The laboratory hardware, software, and Internet connections include ten dSPACE DS1102 Miniboxes and ten Sun SPARCstation 5 workstations [2, 5] as shown in Figure 1. The Miniboxes and Sun workstations communicate through an Internet connection. Each Minibox and workstation has its own IP (Internet Protocol) address and is remotely accessible from any Internet site. The Internet access to the laboratory makes it possible to develop experiments that can be shared among several universities, as

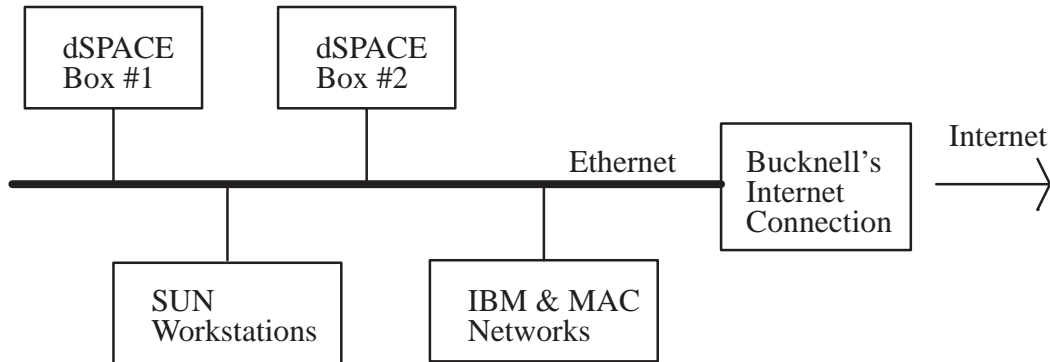

Figure 1: Laboratory components and connections to the Internet.

proposed in [1]. The remotely accessible experiments should be designed so they can be executed without requiring human intervention in the laboratory.

Each Minibox contains a 40 MHz Texas Instruments TMS320C31 digital signal processor along with memory and input/output circuits. The other hardware components of the DS1102 Minibox include the following:

- 128k x 32-bit memory
- two 16-bit and two 12-bit analog-to-digital converters (ADC)
- four 12-bit digital-to-analog converters (DAC)
- 16-bit digital input/output
- ethernet/Internet connections.

The Miniboxes are programmed using either C language or Simulink [7], a graphical interface to Matlab [6]. An additional software tool called TRACE [2] is used to debug Minibox programs and also to transfer measured data from the Minibox to the workstation. Measured data can be analyzed on the workstation using Matlab.

3 Experiment

A first order system unit step response is described by the equation

$$y(t) = A(1 - \exp(-at)), \quad t \geq 0 \quad (1)$$

where A is the gain and $1/\alpha$ is the time constant of the system. The objective of this experiment is to estimate the values of A and α recursively from the sampled data. That is, the estimates of A and α are improved in real-time as each new data point is measured.

Following the approach presented in [2] and [3], we obtain a first-order Taylor series expansion of (1) about a point (A_0, α_0) . Then we minimize the sum of squared differences between the measured data

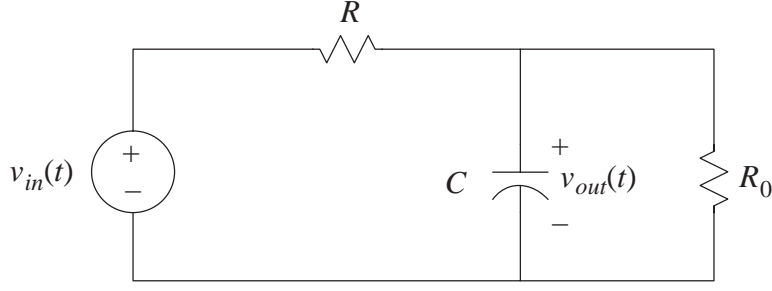

Figure 2: RC circuit.

$y_r(t_1), y_r(t_2), \dots, y_r(t_N)$ and the model in (1) with respect to the parameters A and α . This process leads to the recursive algorithm described next.

The recursive algorithm begins with an initial estimate of $A = A_0$ and $\alpha = \alpha_0$. The next values of A and α are computed by solving for the updates ΔA and $\Delta \alpha$ in (2)

$$\begin{bmatrix} \sum_{i=1}^N f_i^2 & \sum_{i=1}^N f_i g_i \\ \sum_{i=1}^N f_i g_i & \sum_{i=1}^N g_i^2 \end{bmatrix} \begin{bmatrix} \Delta A \\ \Delta \alpha \end{bmatrix} = \begin{bmatrix} \sum_{i=1}^N f_i (y_r(t_i) - A f_i) \\ \sum_{i=1}^N g_i (y_r(t_i) - A f_i) \end{bmatrix} \quad (2)$$

where

$$f_i = 1 - \exp(-\alpha t_i) \quad (3)$$

and

$$g_i = A t_i \exp(-\alpha t_i). \quad (4)$$

The first order system used in the experiment is the RC circuit shown in Figure 2. The objective is to estimate the parameters A and α by observing the output voltage $v_{out}(t)$ when the input voltage $v_{in}(t)$ is a unit step function. In this circuit, $A = R_0/(R + R_0)$ and $\alpha = (R + R_0)/(R R_0 C)$. The parameter estimates are updated in real-time as each data point is measured. Data collection can be stopped when the estimates have converged.

4 Recursive Parameter Estimation Algorithm

The recursive algorithm is implemented using the following steps.

1. Make initial estimates $A = A_0$ and $\alpha = \alpha_0$.
2. Solve equation (2) for ΔA and $\Delta \alpha$ using the first three measurements, $y_r(t_1), y_r(t_2)$, and $y_r(t_3)$ and with $N = 3$.
3. Obtain the new estimates of A and α by forming $A_0 + \Delta A$ and $\alpha_0 + \Delta \alpha$. If either value of A or α is negative, then use the previous value.
4. Measure the next data point, increment N , and evaluate f_i in (3) and g_i in (4) for $i = 1, 2, \dots, N$ using the new values for A and α .
5. Solve equation (2) for ΔA and $\Delta \alpha$, and go to step 3 until the stopping criteria is reached.

Three measurements are used in step 2 so that the estimates are not adversely affected by a single noisy measurement. Step 3 prohibits negative parameter values because they are impossible in the model (1). The algorithm is stopped when ΔA and $\Delta\alpha$ are small.

A variation of the above algorithm is to always use the initial values A_0 and α_0 in the equations (2), (3), (4), resulting in a much simpler implementation with less real-time computation. However, convergence of this variation is much more dependent on the choice of initial conditions. Students can investigate this tradeoff between computational complexity and convergence.

5 Real-Time Implementation and Internet

The dSPACE hardware is used to generate the step input and measure the output voltage as shown in Figure 3. A train of step input signals are generated by the digital-to-analog converter (DAC), and the analog-to-digital converter (ADC) measures both the input and the output voltage of the circuit.

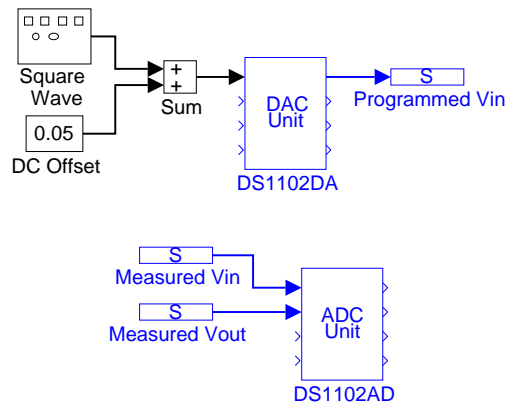

Figure 3: Block diagram for connection of dSPACE hardware to the RC circuit.

The parameter estimation algorithm is implemented in a C program and downloaded into the dSPACE hardware. The simulated and real-time performance of the algorithm are shown in Figures 4 and 5, respectively. The circuit component values in Figure 2 are $C = 50\mu F$ and $R = 500\Omega$ with $R_0 = \infty$. The expected parameter values are $A = 1$ and $\alpha = 40$. The initial values of A and α in both the simulation and the real-time execution are $A_0 = 0.5$ and $\alpha_0 = 32$, and the sampling rate is 1000 samples per second.

The simulation in Figure 4 converges after only 6 time steps. The real-time execution in Figure 5 converges to the values $A = 0.98$ and $\alpha = 41.28$, but more than 6 iterations are needed due to measurement noise. Figure 6 shows that the model in (1) with the parameter values $A = 0.98$ and $\alpha = 41.28$ obtained after convergence in Figure 5 provides a good fit to the measured data. The measured data reaches a final value that is less than 1 volt because the DAC loads the circuit and produces an effective $R_0 = 100k\Omega$ in the circuit of Figure 2.

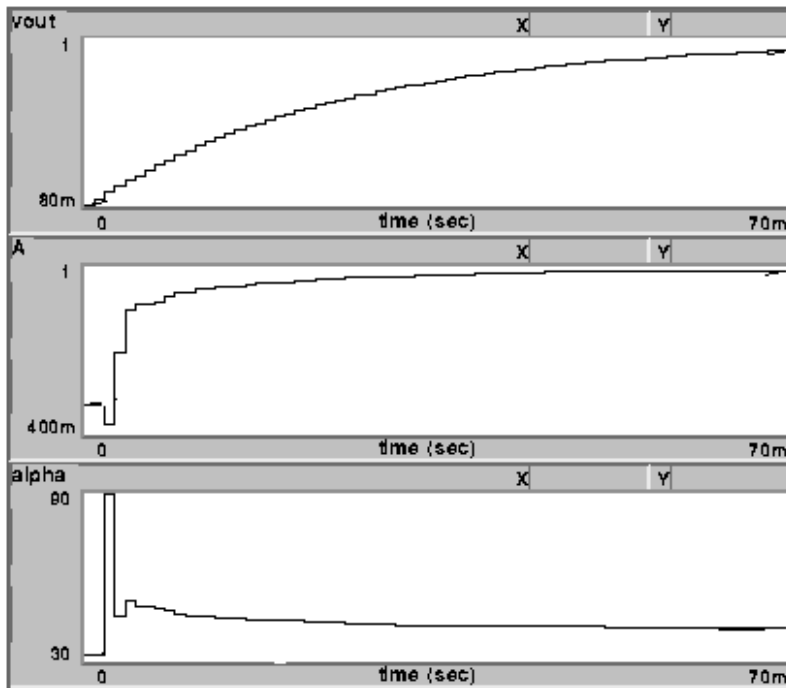
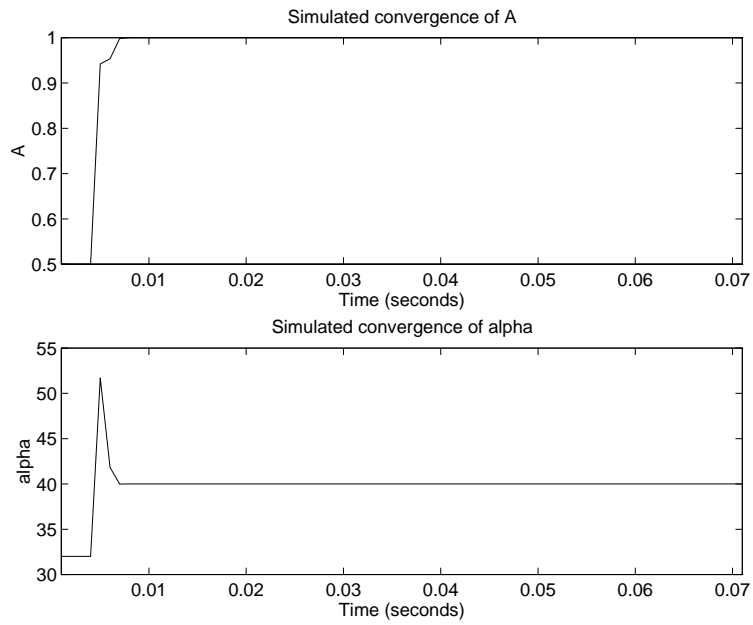

Figure 5: Trace of measured output voltage and convergence of A and α during real-time execution.

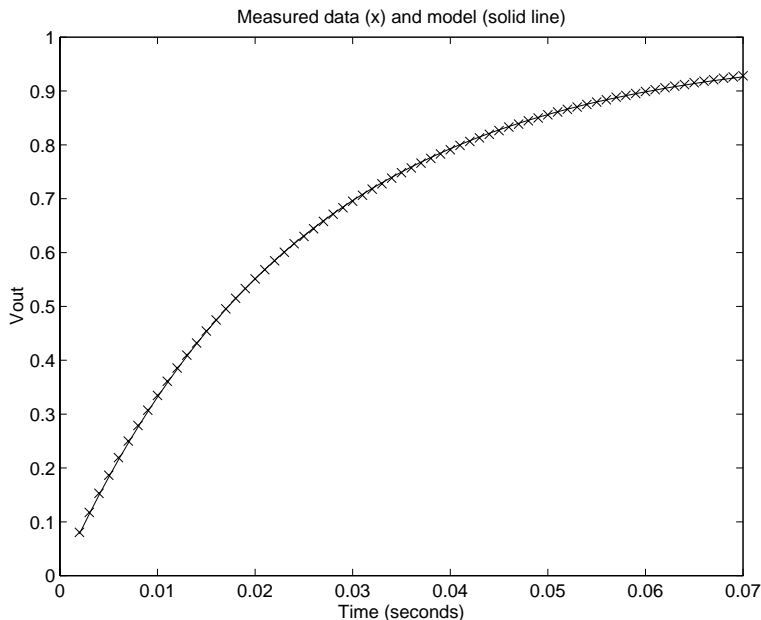

Figure 6: Measured output voltage and the model (1) evaluated with $A = 0.98$ and $\alpha = 41.28$ obtained from the real-time trace in Figure 5 after convergence.

The measured data presented in Figures 5 and 6 was acquired through an Internet connection to the dSPACE hardware, and the experiment itself was controlled through the Internet. Internet access to the experiment is currently available within the Bucknell University campus and through remote login (telnet) to a Bucknell University computer. The World Wide Web provides a more convenient interface for remote execution of the experiment, and we are currently developing a Web interface. The goal is to create a Web page that allows a remote user to execute the experiment, view the measured data, and download the measured data to the user's host computer.

6 Summary

We have described a recursive parameter estimation method for first-order systems. The method reinforces and integrates mathematical and statistical techniques in an engineering experiment. In addition, students can simulate the convergence of the algorithm with noisy data, compare the model output with the measured data, test the convergence with various initial conditions, investigate the suggested variation of the algorithm for reduced computation, determine the effects of sampling time and the number of iterations on the convergence of the algorithm, and investigate the loading effects of the dSPACE hardware. The experiment is currently accessible via Internet if a remote user logs into a computer located at Bucknell University. We are developing a World Wide Web interface that will permit a remote user to execute the experiment and retrieve the measured data.

Acknowledgment

This material is based upon work supported by the National Science Foundation under Grant No. DUE-9451618.

References

- [1] M.F. Aburdene, E.J. Mastascusa, and R. Massengale, "A proposal for a remotely shared automated laboratory," *1991 IEEE/ASEE Frontiers in Education Conference*, pp. 589-592, Sept. 1991.
- [2] dSPACE digital signal processing and control engineering GmbH, *DS1102 Software Environment* (Reference Guide), Germany, 1994.
- [3] R. Micheletti, "Dynamic parameter estimation of a second-order system to a step function," *IEEE Trans. Instrum. and Meas.*, vol. 38, no. 5, pp. 790-792, Oct. 1990.
- [4] M.F. Aburdene and J. Andersen, "Dynamic parameter estimation using frequency domain data," *Computers in Education Journal*, vol. II, no. 2, pp. 1-15, April-June 1992.
- [5] R.J. Kozick and C.C. Crane, "An integrated environment for modeling, simulation, digital signal processing, and control," to appear in *IEEE Trans. Education*, May 1996.
- [6] The Mathworks, Inc., *The Student Edition of MATLAB*, Natick, Massachusetts, 1992.
- [7] The Mathworks, Inc., *SIMULINK: Dynamic System Simulation Software* (Users's Guide), Natick, Massachusetts, 1992.

RICHARD J. KOZICK has been an Assistant Professor in the Electrical Engineering Department at Bucknell University since 1993. He was a Member of Technical Staff at AT&T Bell Laboratories from 1986 to 1989 and again from 1992 to 1993. He received the Ph.D. degree from the University of Pennsylvania, M.S. from Stanford University, and B.S. from Bucknell University. His research interests are in the areas of signal processing and communications.

MAURICE F. ABURDENE is the T. Jefferson Miers Professor of Electrical Engineering and Professor of Computer Science at Bucknell University. He has also taught at Swarthmore College, State University of New York at Oswego, and the University of Connecticut. Professor Aburdene was a project engineer and project manager at the Bristol Company, a visiting research scientist at MIT's Laboratory for Information and Decision Systems, and held various summer fellowships with NASA and the Naval Research Laboratory.